

What You Can't See

*Findings from the Commonwealth of Massachusetts
Direct Vision Study*

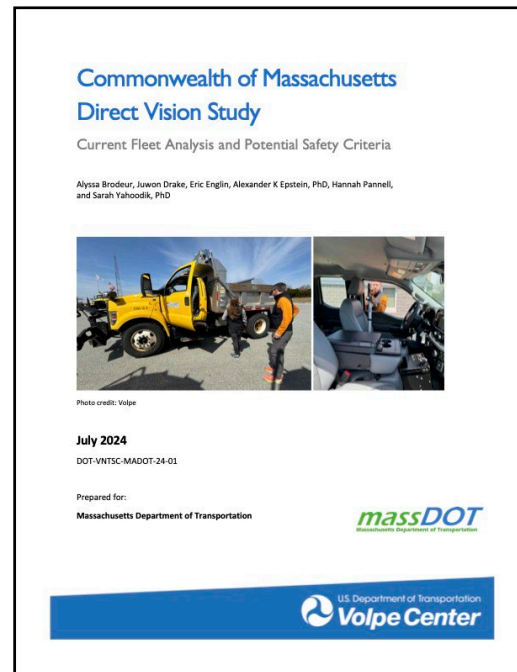

The Lab @ MassDOT
Kris Carter
November 14, 2024

Car and Truck Bloat
are having a moment of increased attention

The Economist

- China's looking-glass economy
- Germany's radicals rise
- Where Elon Musk is right
- Mexico's democracy at risk

SEPTEMBER 7TH-13TH 2024

AMERICA'S KILLER CARS



07-24-2024 | IMPACT

FASTCOMPANY

SUBSCRIBE

Why car companies might finally have to care about pedestrian safety

The Biden administration is finally taking a stand against car bloat.



More Pedestrians Have Been Killed in Single-Vehicle Crashes as the Share of New Large-Car Sales Increased

Reported number of pedestrian fatalities

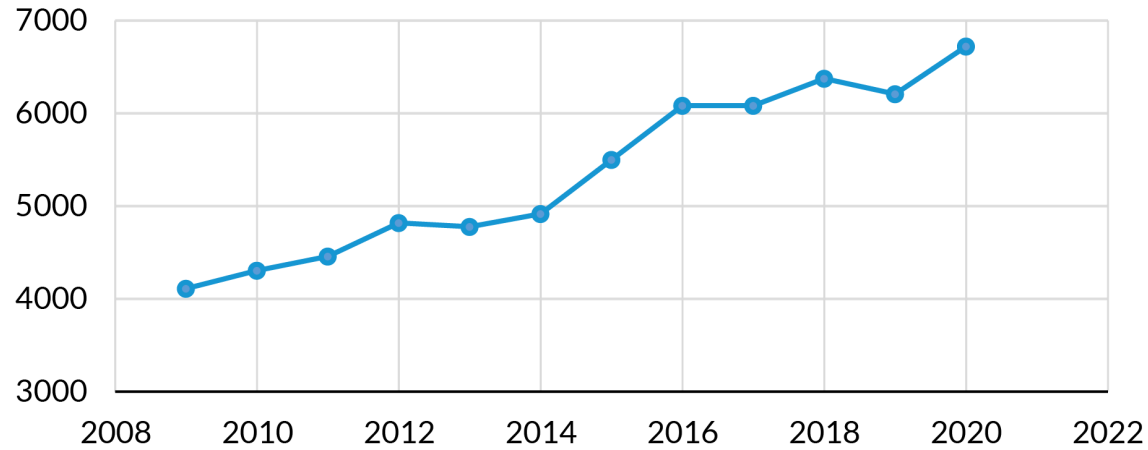

Share of vehicle sales that are large cars

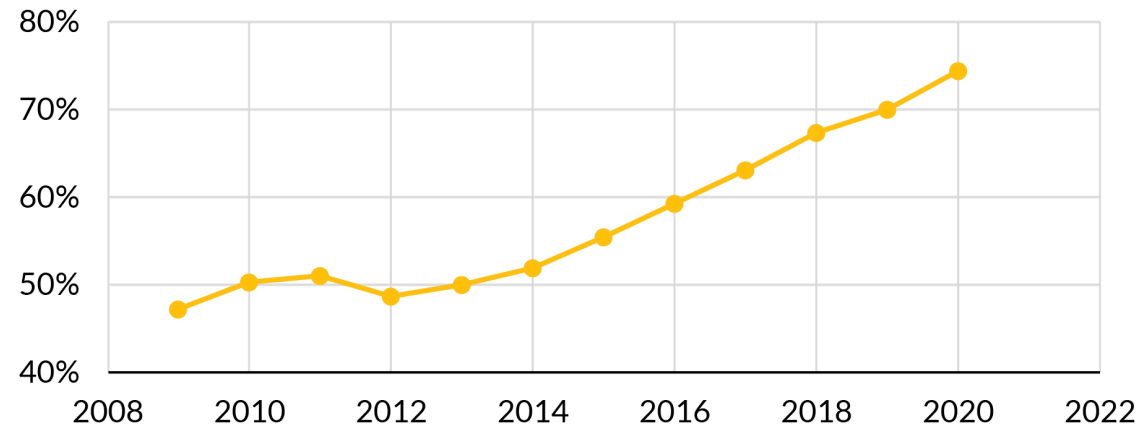

Sources: Fatality Analysis Reporting System, Federal Reserve Economic Data, and Governors Highway Safety Association.

Note: Large cars are SUVs, pickup trucks, and minivans.

URBAN INSTITUTE

massDOT
Massachusetts Department of Transportation

Large Truck Safety Context

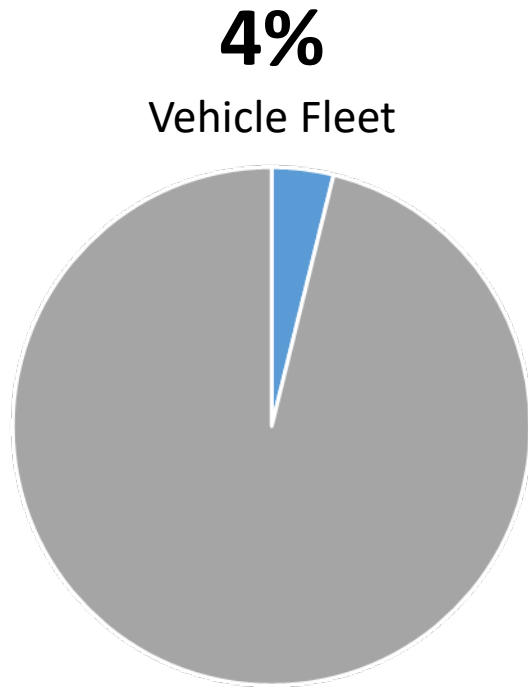

U.S.

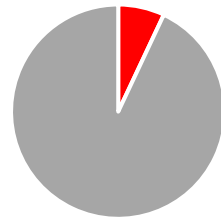

8%

Pedestrian Fatalities

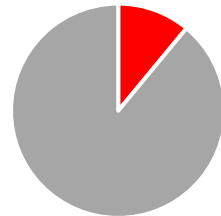

11%

Bicyclist Fatalities

NYC

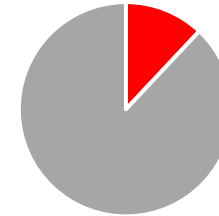

12%

Pedestrian Fatalities

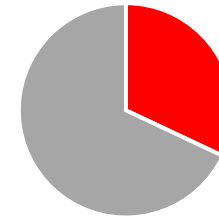

32%

Bicyclist Fatalities

631 truck-VRU fatalities in 2021

<https://www.fmcsa.dot.gov/sites/fmcsa.dot.gov/files/2022-01/FMCSA%20Pocket%20Guide%202021.pdf>

https://www.nyc.gov/html/dot/downloads/pdf/nyc_ped_safety_study_action_plan.pdf

<https://www.nyc.gov/html/dot/downloads/pdf/bicyclefatalities.pdf>

Cyclist Killed in Crash in Boston Involving Tractor-Trailer

The crash occurred at the intersection of Massachusetts and Harrison avenues, near the Boston Medical Center

By **Melissa Buja** • Published April 22, 2020 • Updated on April 22, 2020 at 5:25 pm

Bicyclist killed by truck is remembered as skilled surgeon, scientist

By **Laura Crimaldi** Globe Staff, August 8, 2015, 10:02 p.m.



Bicyclist fatally struck by UPS truck in Newton, authorities say

Share



Updated: 11:58 PM EDT Aug 28, 2023

Infinite Scroll Enabled



Russ Reed



Bicyclist dies after being hit by truck in Cambridge, police say

The bicyclist, whose name wasn't released, was taken to the hospital, where she died from her injuries, police said

By **Michael Rosenfield** • Published June 21, 2024 • Updated on June 21, 2024 at 11:50 pm

Tractor-Trailer Fatally Strikes Bicyclist in Harvard Square

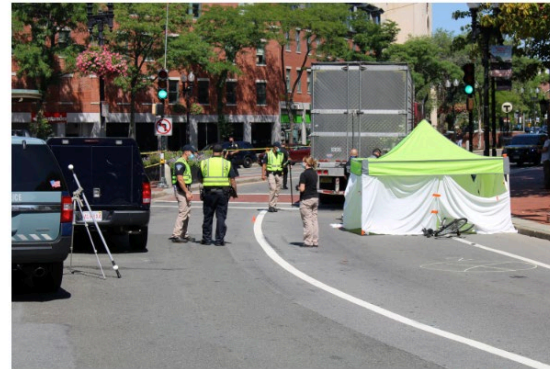

A fatal accident shut down Harvard Square Tuesday morning and afternoon. By **Aidan F. Ryan**

Cyclist Killed in Crash in Boston Involving Tractor-Trailer

The crash occurred at the intersection of Massachusetts and Harrison avenues, near the Boston Medical Center

By **Melissa Buja** • Published April 22, 2020 • Updated on April 22, 2020 at 5:25 pm

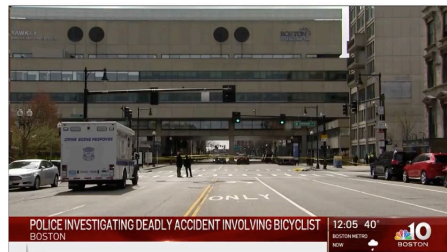

Trending Stories

- NEW ENGLAND BY NFL fans amp up Belichick's sass flag throw in Pa
- MASSACHUSETTS Gov. Healey to D agencies from single-use plast
- MASSACHUSETTS Traffic nightmare shuts down dur commute after crash
- NEW HAMPSHIRE Driver of truck & motorcycle kill with DWI

CRASHES

Truck Driver Kills 5-Year-Old Girl In a Downtown Andover Crosswalk

3:44 PM EDT on May 15, 2023



BICYCLING

Truck Driver Kills Cambridge Man Next to Symphony Hall in Boston

11:37 AM EDT on July 14, 2022

Cyclist Struck And Killed By Dump Truck Outside Museum Of Science

Updated November 09, 2018

By **WBUR Newsroom**



Jury clears armored truck driver in 2005 death of cyclist Margaret 'Meg' Sanders in Northampton

By **BOB DUNN** Staff Writer

Last modified: Friday, April 26, 2013



**Drivers can't
avoid what
they can't
see.**



What is Direct Vision?



When drivers have **direct vision** of a pedestrian,
they can react up to 50% faster.



Source: FHWA.

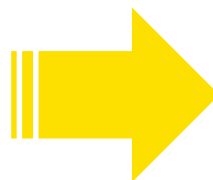

2023 Massachusetts Strategic Highway Safety Plan 27

Take an Active Role to Affect Change in Vehicle Design, Features, and Use

Safe vehicles are a core component of a Safe System Approach, as vehicle sizes and designs affect the occurrence and severity of collisions.

Cars are manufactured with the capability to reach speeds up to 212 mph—more than 3 times the highest speed limit in Massachusetts—and many vehicles sold in the U.S. can accelerate from 0 to 60 mph in under 3 seconds.²⁵ Further, vehicles weigh thousands of pounds and the average vehicle size has increased with more drivers choosing SUVs and pick-up trucks. **The Commonwealth should have an active role in expanding the availability of vehicle systems and features, restrict use of certain vehicles, and explore different options for expanding licensing types based on types of vehicles, to prevent and minimize the impacts of crashes.**

25 <https://www.motortrend.com/features/fastest-cars-0-60-mp/h/>

Commonwealth Direct Vision Study



Measure Commonwealth-owned vehicles



Collaborate with 10 municipalities

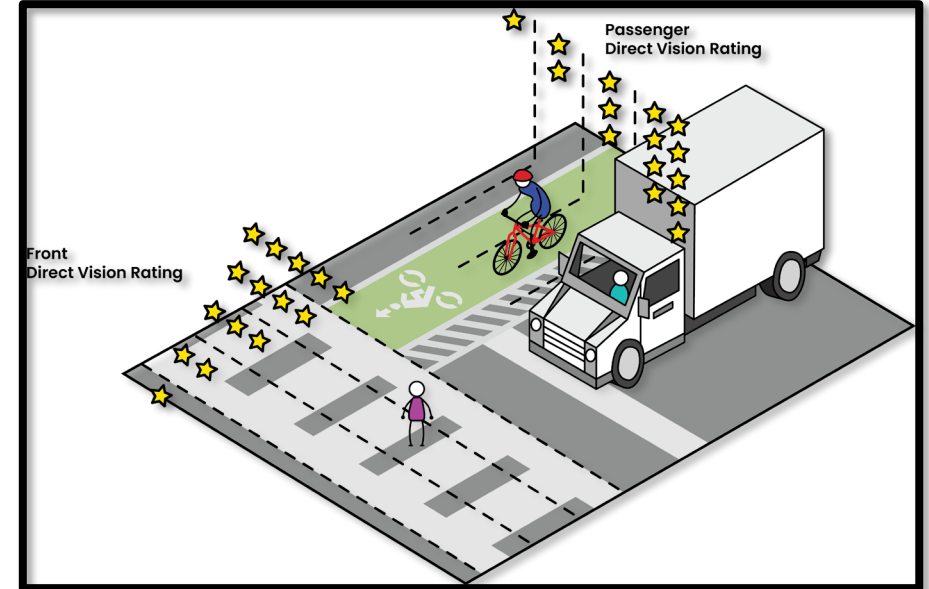

Produce a report and Direct Vision rating system

Study Findings

1

**Downsize
the vehicle
whenever
possible**

On average, light - duty vehicles have the highest visibility. Picking the smallest vehicle possible affords better visibility

Recommendation from the Study: Encourage Downsizing



Photo credit:
Thom Shavor

Weight Class	% of Vehicles with a Front Direct Vision Rating of 3+ Stars	% of Vehicles with a Passenger Direct Vision Rating of 3+ Stars
Light	87.5% (7/8 vehicles)	100% (8/8 vehicles)
Medium	70% (14/20 vehicles)	70% (14/20 vehicles)
Heavy	27% (6/22 vehicles)	9% (2/22 vehicles)

Study Findings

2

Drivers in heavy duty vehicles cannot easily see people on the street

- 50% of heavy - duty vehicles cannot see a child in the crosswalk

90% of heavy - duty vehicles cannot see a child in a bike lane

Heavy Duty Vehicles

Full Report available at
[tinyurl.com /MA - dv - study](https://tinyurl.com/MA-dv-study)

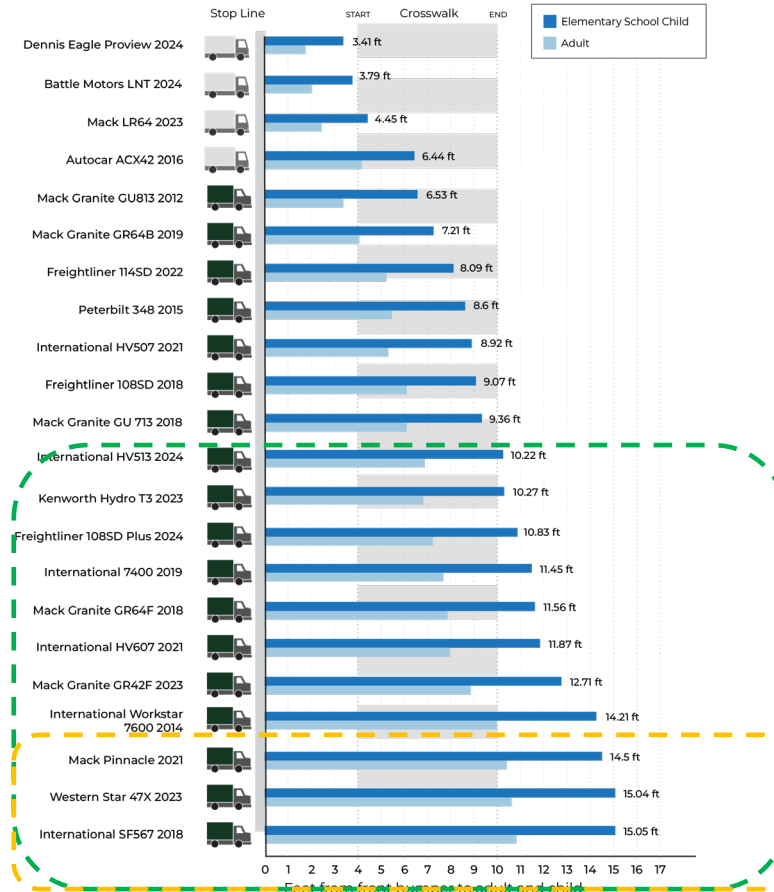
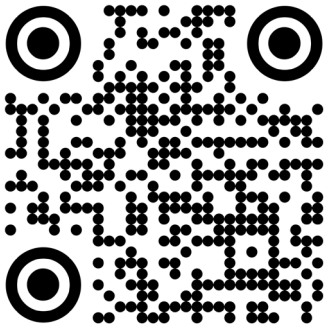

Cannot see a child in the crosswalk

Cannot see a child or an adult in the crosswalk

Visibility at a Crosswalk
 Who can a driver see?

Heavy Duty Vehicles

Full Report available at [tinyurl.com /MA - dv - study](https://tinyurl.com/MA-dv-study)

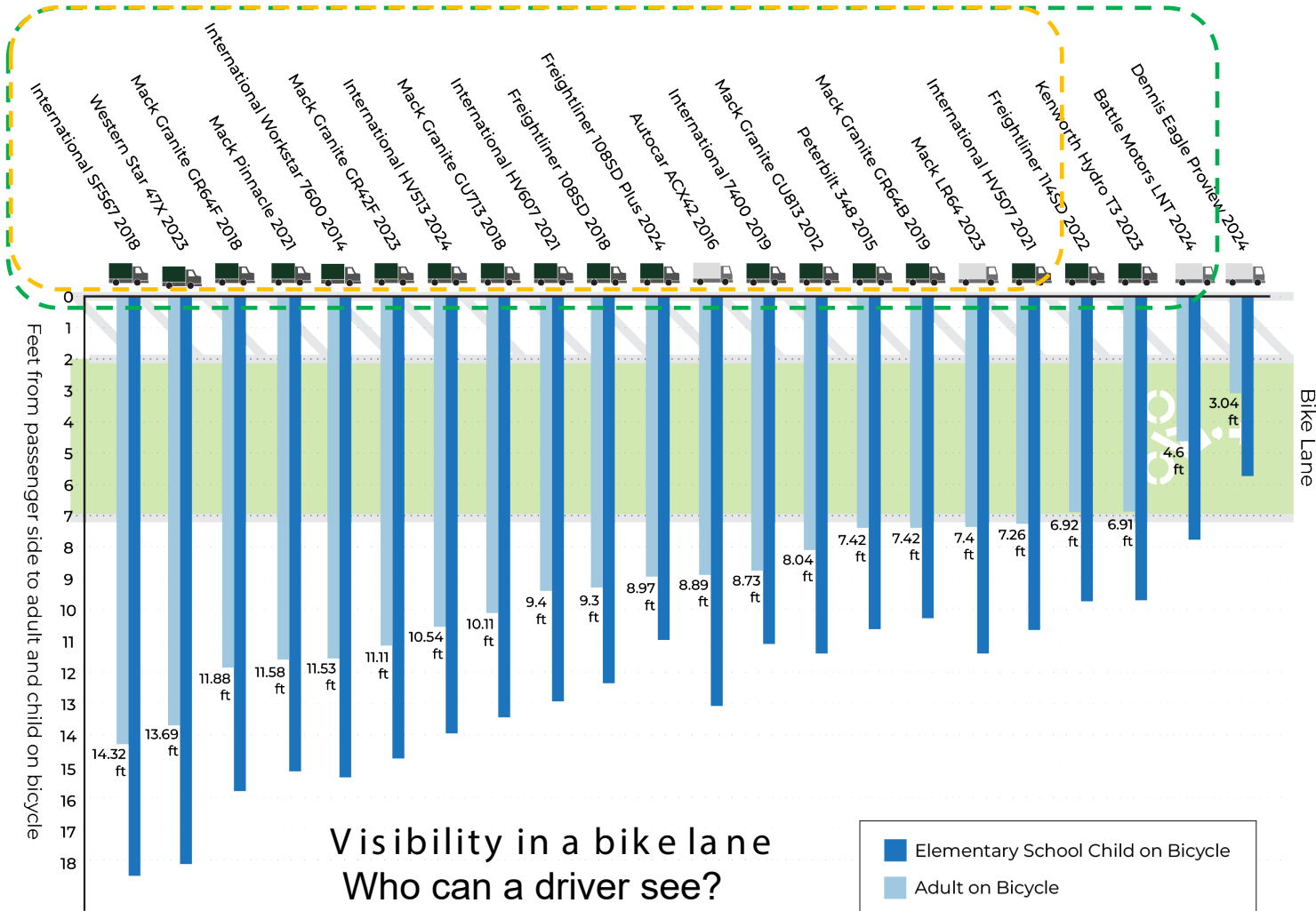

Cannot see a child in the bike lane

Cannot see a child or an adult in the bike lane

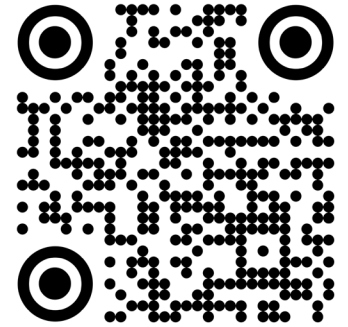

Study Findings

3

**Driver
visibility
is mostly
getting
worse**

Visibility in weight class 3 and 4 vehicles appears to be decreasing in newer generations of legacy models.

Driver Visibility Maps

where a driver can see the ground

2022 Ford F-150

Light Duty - Class 1

Front ★★★★★☆

Passenger ★★★★★☆

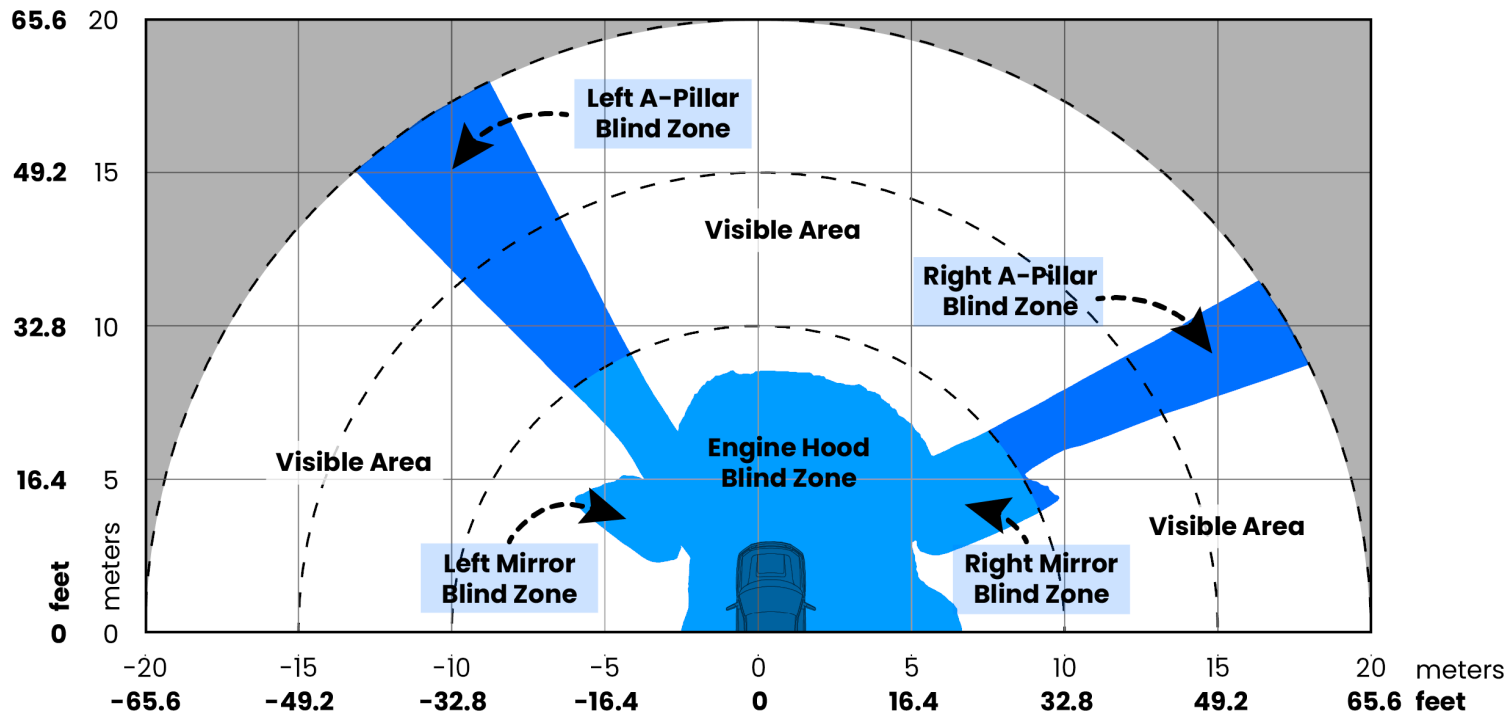

Driver Visibility Maps

where a driver can see the ground

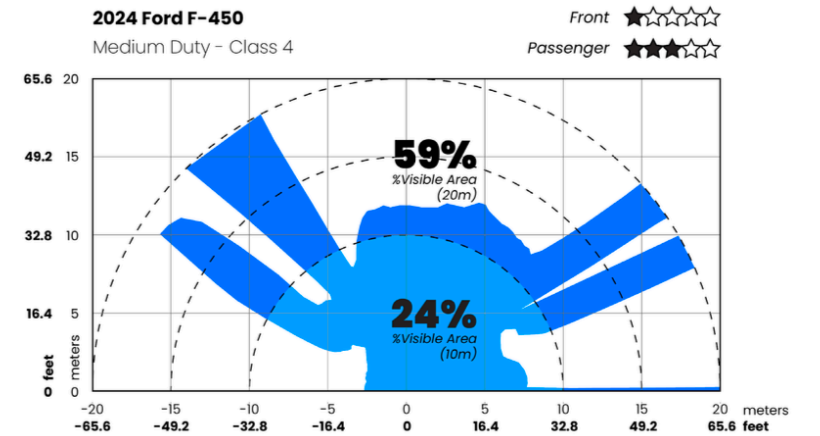
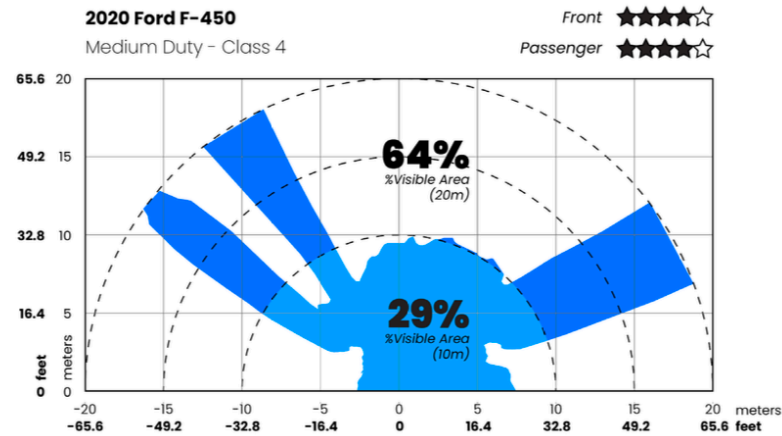
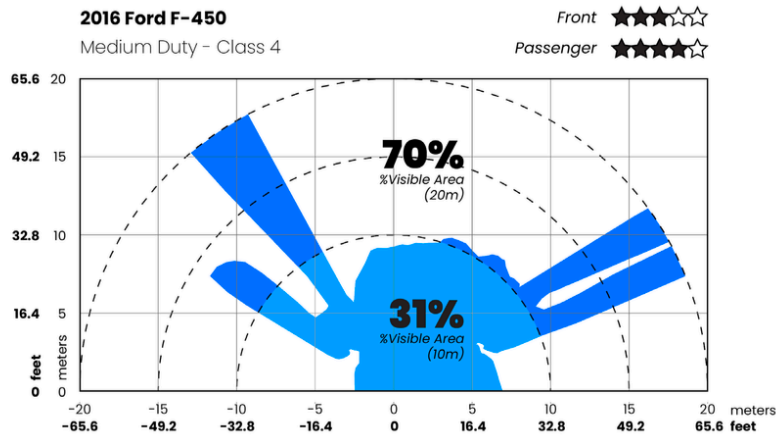

From 2016 to 2024 in the F - 450, the visible area at 10 meters decreased by 7% and at 20 meters decreased by 11%

Driver Visibility Maps

where a driver can see the ground

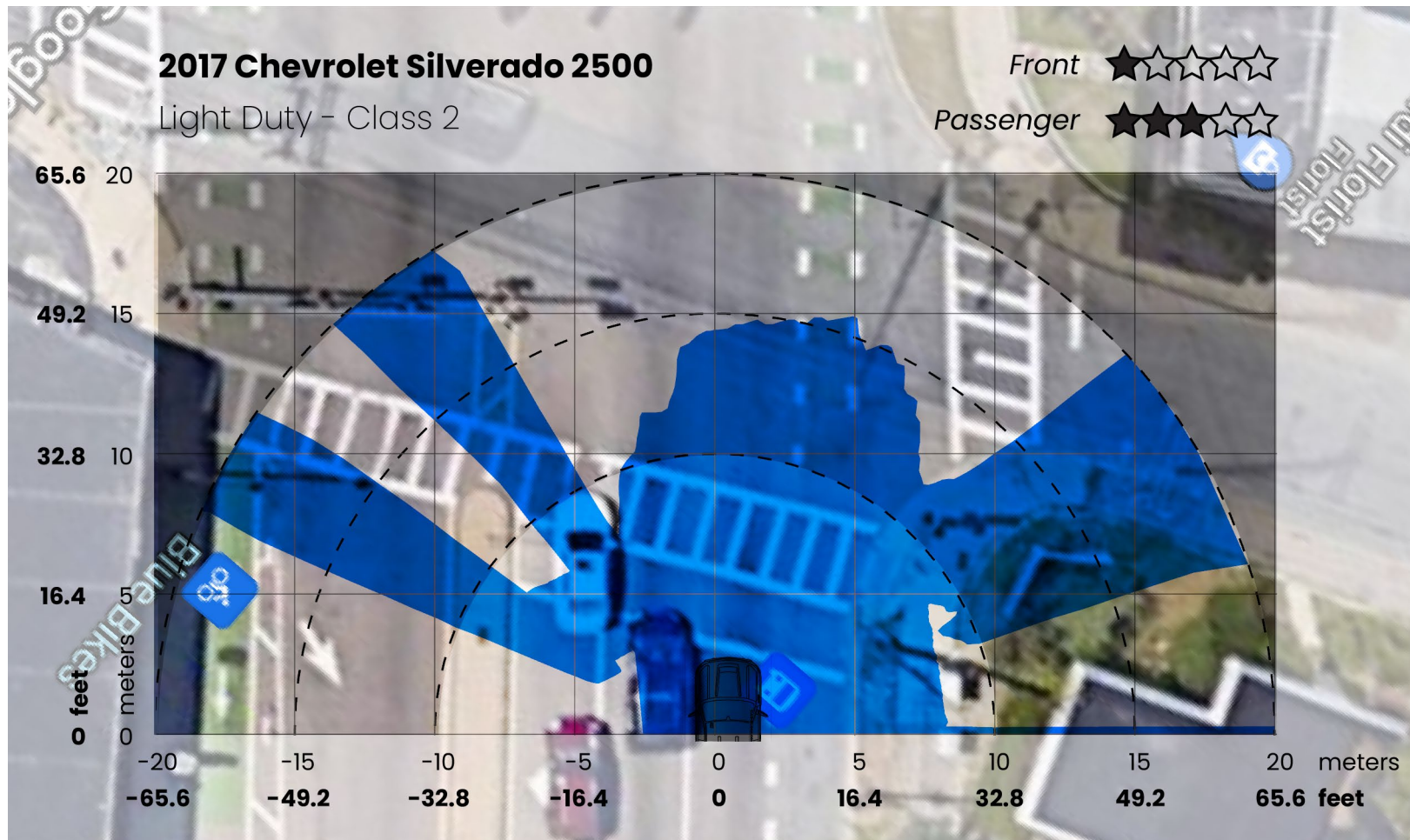



What can we do?

Manage a fleet?

Measure. Match. Migrate.

Direct Vision Ratings for Heavy-Duty Vehicles

Make/Model/Year	Front DV Rating	Side DV Rating
Dennis Eagle Proview 2024	★★★★★	★★★★☆
Battle Motors LNT 2024	★★★★★	★★★★☆
Mack LR64 2023	★★★★☆	★★★☆☆
Mack Granite GR64B 2019	★★★★☆	★★★☆☆
Autocar ACX42 2016	★★★★☆	★★☆☆☆
Mack Granite GU813 2012	★★★☆☆	★★★☆☆
Freightliner 114SD 2022	★★★★☆	★★☆☆☆
Peterbilt 348 2015	★★★☆☆	★★★☆☆
International HV507	★★★☆☆	★★★☆☆
Freightliner 108SD 2018	★★★☆☆	★★☆☆☆
Mack Granite GU 713 2018	★★★☆☆	★★☆☆☆
Kenworth Hydro T3 2023	★★☆☆☆	★★★☆☆
International HV513 2024	★★☆☆☆	★★☆☆☆
Freightliner 108SD Plus 2024	★★☆☆☆	★★☆☆☆
International 7400 2019	★★☆☆☆	★★☆☆☆
Mack Granite GR64F 2018	★★☆☆☆	★★☆☆☆
International HV607 2021	★★☆☆☆	★★☆☆☆
Mack Granite GR42F 2023	★★☆☆☆	★★☆☆☆
International Workstar 7600 2014	★★☆☆☆	★★☆☆☆
Mack Pinnacle 2021	★★☆☆☆	★★☆☆☆
Western Star 47X 2023	★★☆☆☆	★★☆☆☆
International SF567 2018	★★☆☆☆	★★☆☆☆

Prototype Star Rating System
Listing all vehicles measured

The 5-Star Rating System

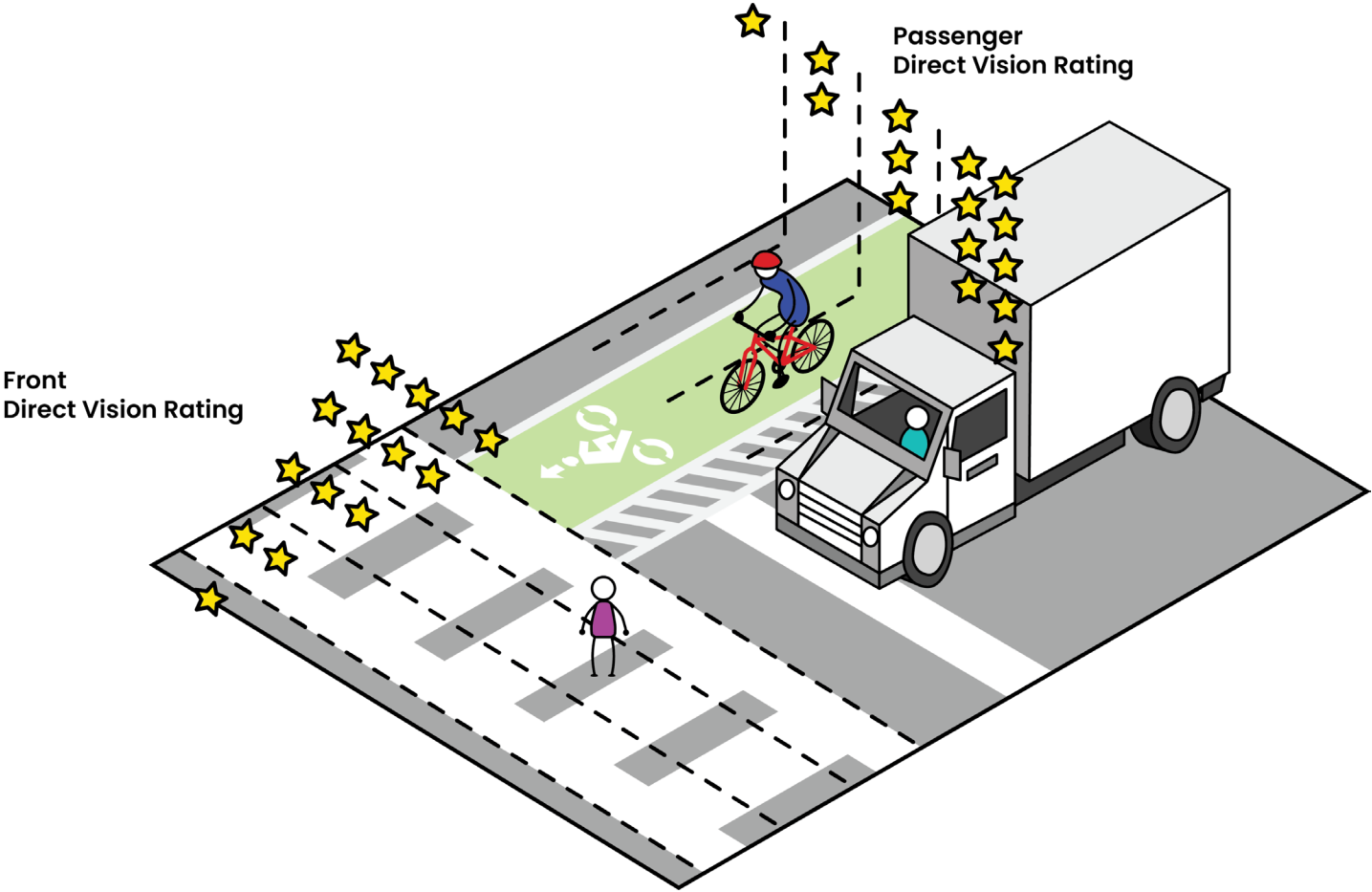

Front Direct Vision Rating

Child first visible	< 4 ft	★★★★★
	4-6 ft	★★★★
	6-8 ft	★★★
	8-10 ft	★★
	> 10 ft	★

Passenger Direct Vision Rating

Child first visible	< 3 ft	★★★★★
Adult first visible	< 3 ft	★★★★
	3-6 ft	★★★
	6-8 ft	★★
	> 8 ft	★

Self Measurement of Vehicles: **The Cone Method**

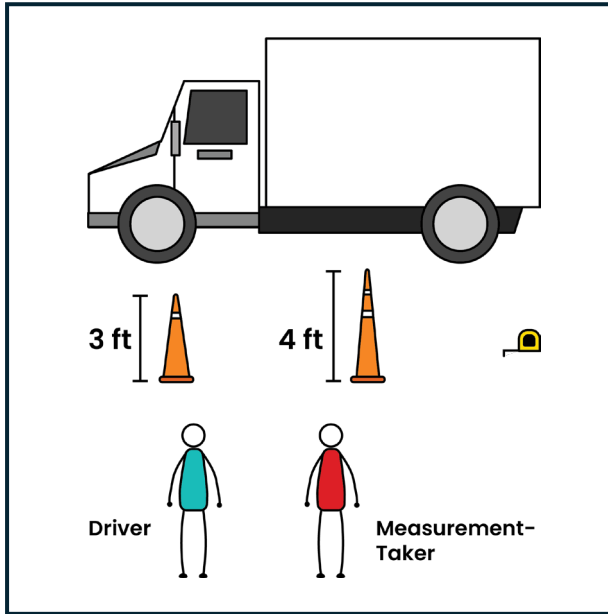

Materials Needed

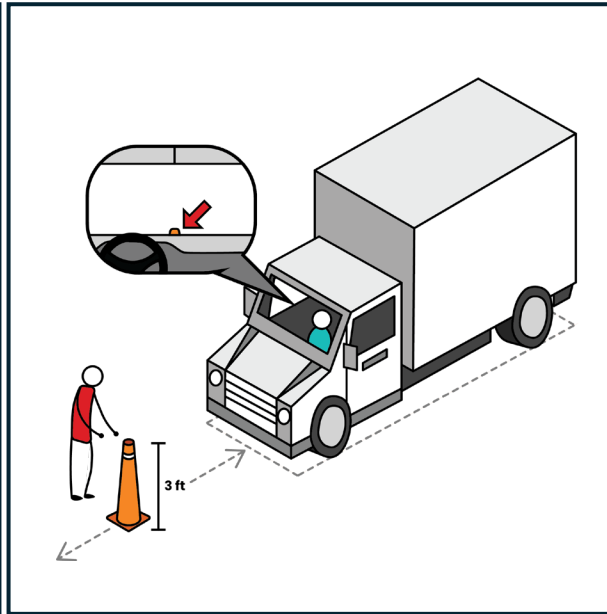

Step 1:
Measurement A

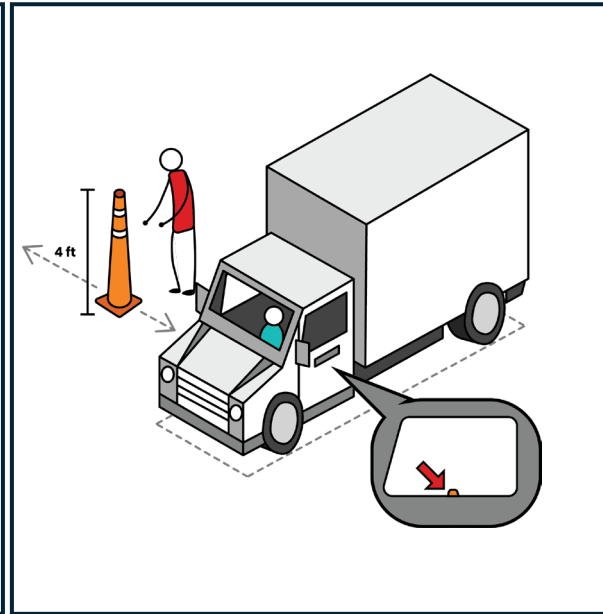

Step 2:
Measurement B

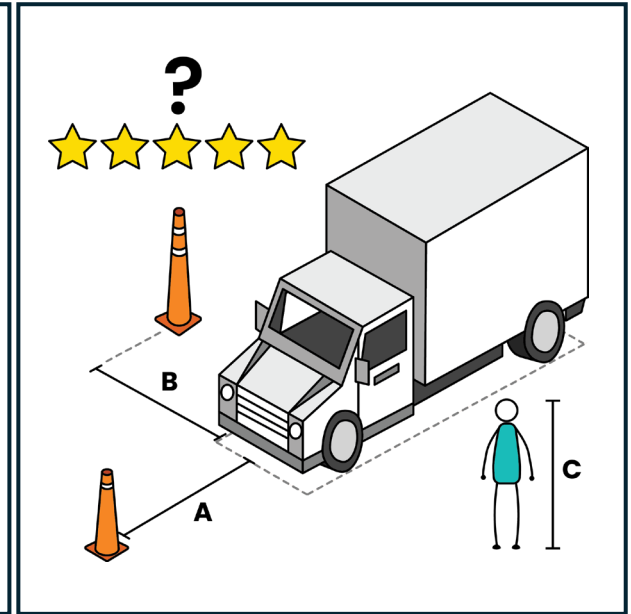

Check the Ratings!

Match the worst vehicles with countermeasures

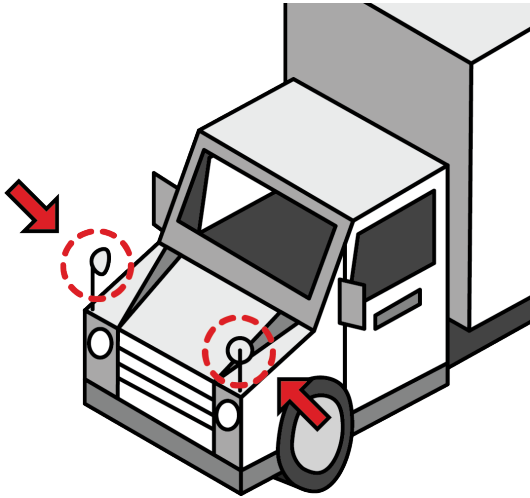

Cross-over Mirrors,
Blind Spot Information
Systems, or Moving Off
Information Systems



Backup or Surround
Cameras, Backup
Sensors, White - noise
alarms

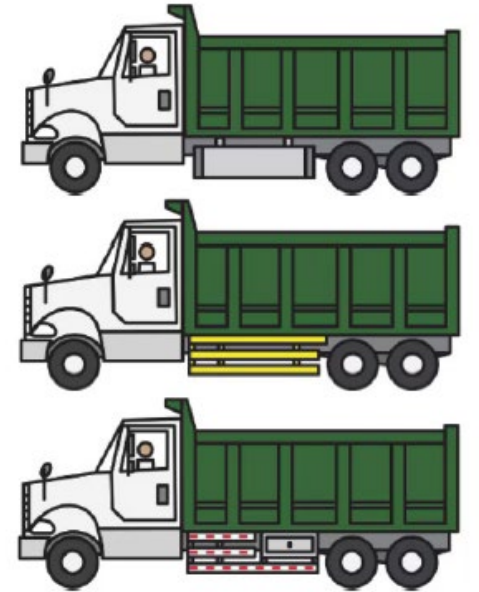

Side Guards and other
Lateral Protective
Devices (LPDs)

Migrate when buying new vehicles : Cab-over or Cab-forward > Conventional

2024 REE P7C

Medium Duty - Class 4

Front ★★★★★

Passenger ★★★★★

2024 Ford F-450

Medium Duty - Class 4

Front ★☆☆☆☆

Passenger ★★★☆☆

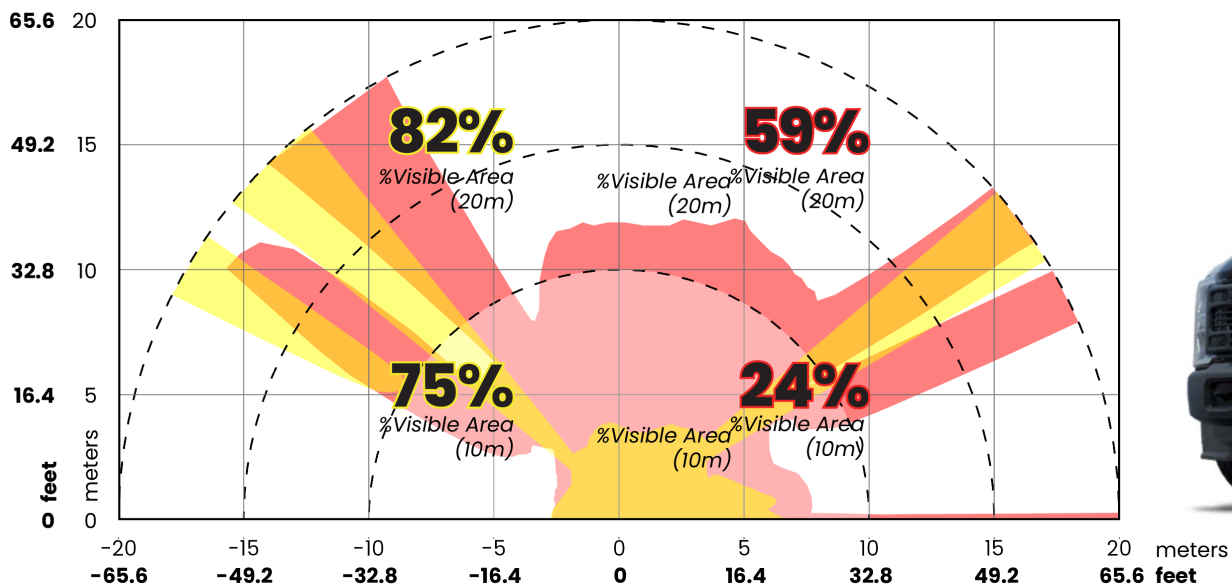

← NEWS

NHTSA Proposes New Vehicle Safety Standard to Better Protect Pedestrians

Would require passenger vehicles to be designed to reduce pedestrian deaths and injuries

Share: [f](#) [X](#) [in](#) [✉](#)

September 9, 2024 | Washington, DC

The National Highway Traffic Safety Administration is advancing pedestrian safety by [proposing a new rule](#) to reduce fatalities and serious injuries among pedestrians struck by vehicles. The proposed rule would establish a new Federal Motor Vehicle Safety Standard requiring new passenger vehicles be designed to reduce the risk of serious-to-fatal injuries in child and adult pedestrian crashes.

Massachusetts Truck Safety Device Law

for state owned, leased, and contracted vehicles over 10,000lbs

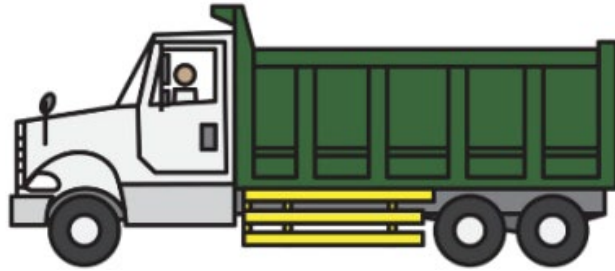

Side guards

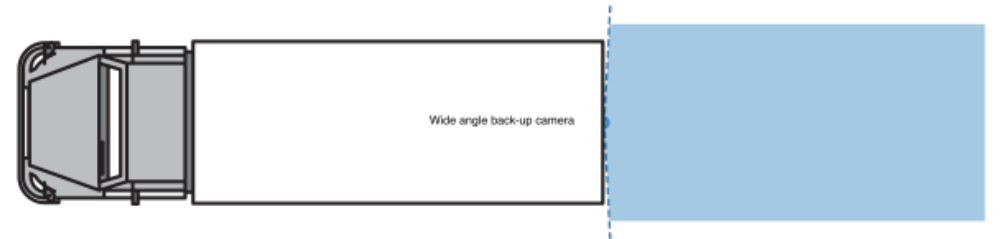

Back - up cameras

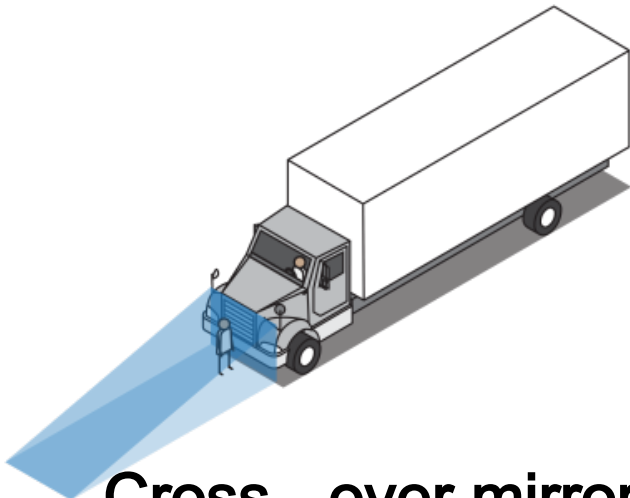

Cross - over mirrors

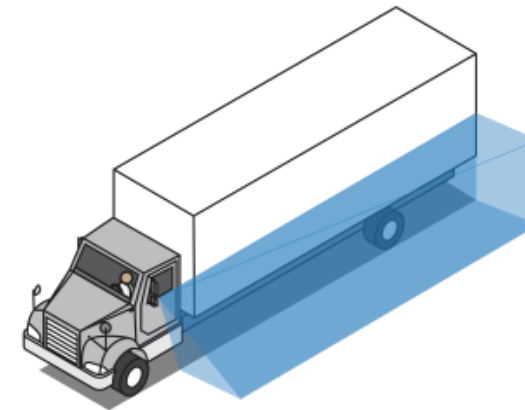

Convex side mirrors

Experiential learning

Empathy at the Intersection exhibit at the MassDOT Innovation Conference & coming to the TRB Annual Meeting 2025



Questions & Discussion



Commonwealth Direct
Vision Report

[tinyurl.com/MA - dv - study](https://tinyurl.com/MA-dv-study)

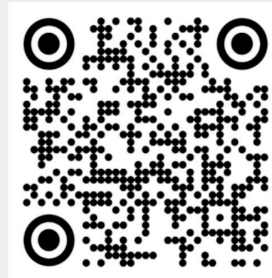

Measurement
Card*

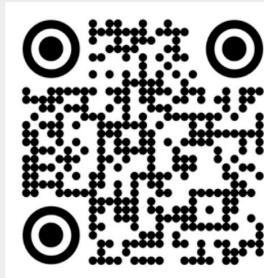

Visual Guide**

Fleet Measurement Resources
from *Together for Safer Roads*

[Tinyurl.com/ tsr - dv - rating - guide](https://tinyurl.com/tsr-dv-rating-guide)



The Lab @ MassDOT

[mass.gov/the - lab - massdot](https://mass.gov/the-lab-massdot)

e: TheLab@massdot.state.ma.us